



GARDENIQUE®

Patio Pond with Lighted Spillway

ITEM # PPRIBRB45/PPIBRW45/PPIGRB45/PPIGRW45

REMINDER

CALL 1-888-755-5641
BEFORE RETURNING TO STORE.



Questions, problems, missing parts? Before returning to your retailer, call our customer service department at 1-888-755-5641, 8 a.m.-6 p.m., EST, Monday-Friday, or email us at customercare@gardeniquedecor.com. Or visit our website www.gardeniquedecor.com.

PACKAGE CONTENTS

Part	Description	Quantity
A	Pump	1
B	Prefilter	1
C	Hose clamp	1
D	Aluminum trim	1
E	Planter basket	1
F	Lighted spillway	1
G	Upper section	1
H	Lower section	1
I	Corner protector	6
J	Transformer	1
K	1" ID tubing (3 feet)	1
L	Stopper	1
M	1/2" tubing	1
N	Bolt	3
O	Liner patch kit	1

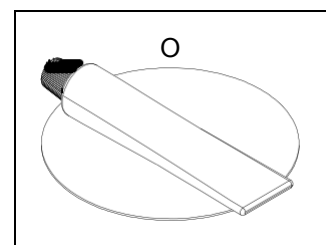
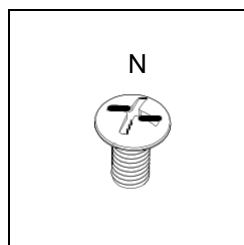
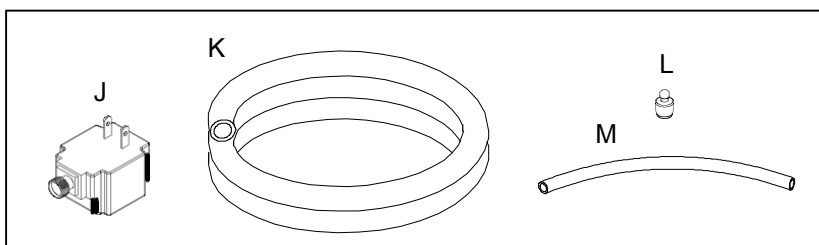
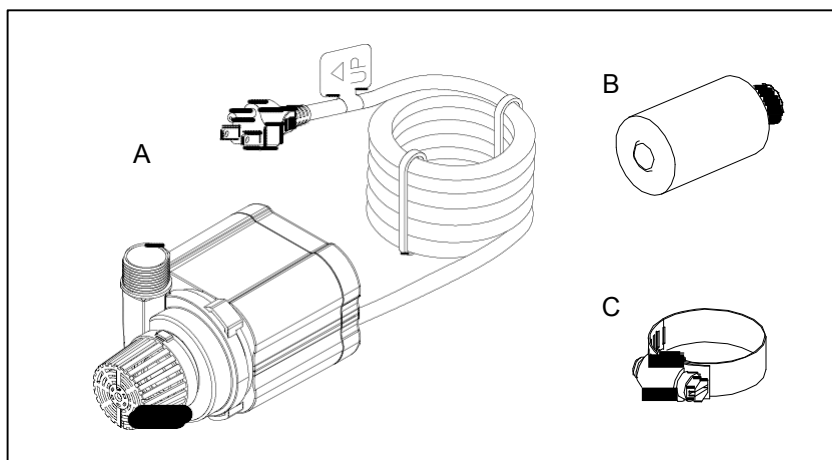
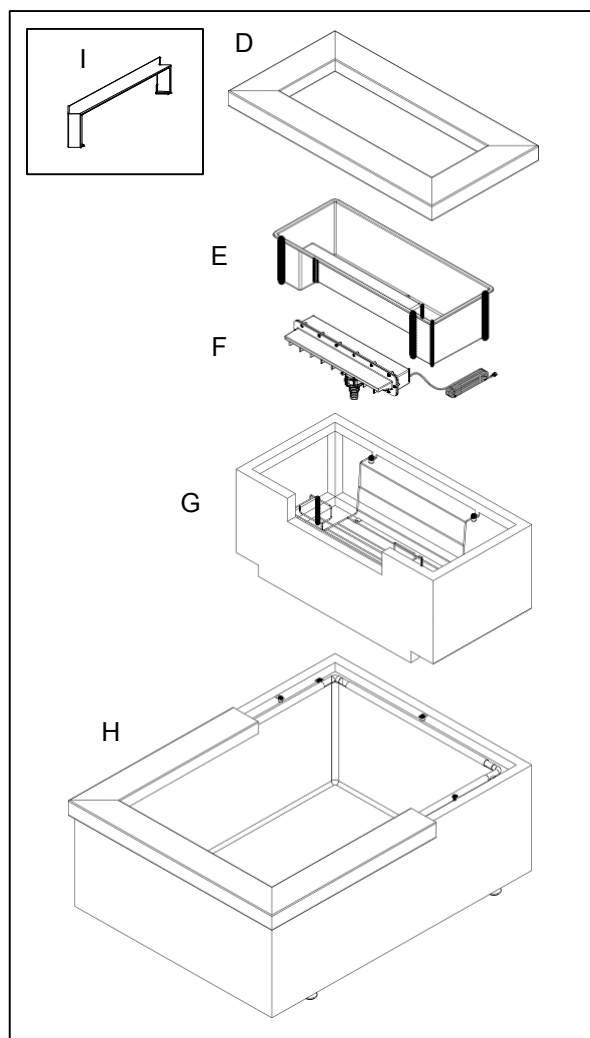

PLEASE CALL 1-888-755-5641 BEFORE RETURNING TO THE STORE.



WARNINGS AND CAUTIONS – PUMP

WARNING

Risk of electrical shock. This pump is supplied with a grounding conductor and grounding-type attachment plug. To reduce the risk of electric shock, be certain that it is connected only to a properly grounded, grounding-type receptacle.

Do not exceed the voltage shown on the pump.

Always disconnect pump from the power source before beginning any maintenance or work on the pump.

Inspect cord for damage before installation and/or maintenance. Replace the entire pump assembly if damage is found.

Do not remove the grounding pin from the power cord plug.

Risk of electrical shock: This pump has not been investigated for use in swimming pools or marine areas.

CAUTION

This pump has been evaluated for use with fresh water only.

Use a proper power source as indicated on the pump label.

Keep the cord away from high temperatures or other heat sources.

Do not pump heated liquids.

Do not let the pump run dry. Pump must be completely submerged for proper operation and cooling.

Operate in fresh water only. Avoid heavily chlorinated water and water with high pH levels.

Do not lift the pump by its power cord.



WARNINGS AND CAUTIONS – SPILLWAY

WARNING

To reduce the risk of electrical shock, connect only to a properly grounded, grounding type receptacle .

Do not exceed the input voltage shown on the transformer.

Do not submerge the transformer.

To reduce the risk of fire or injury, keep lamp away from materials that may burn.

Always disconnect light from the power source before beginning any maintenance or work on the light.

Inspect cord for damage before installation and/or maintenance. Replace the entire light/transformer assembly if damage is found.

CAUTION

Use a proper power source as indicated on the transformer label.

Keep the cord away from high temperatures or other heat sources.

Do not lift the light or the transformer by its power cord.

This light assembly is not intended for use in swimming pools or hot tubs.



PLEASE CALL 1-888-755-5641 BEFORE RETURNING TO THE STORE.

PREPARATION

Before beginning assembly or operation of product, make sure all parts are present. Compare parts with package contents list and diagram above. If any part is missing or damaged, do not attempt to assemble, install or operate the product. Contact customer service for replacement parts.

Estimated Assembly Time: 15 minutes

Tools required for assembly: flathead screwdriver, hacksaw.

OPERATION INSTRUCTIONS

1. Select a level location to assemble the Patio Pond. Then place the upper section on to the lower section. Fig. 1

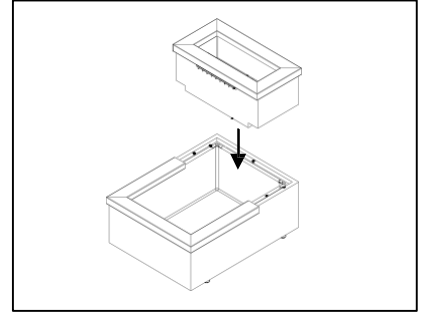

Fig. 1

2. Remove the aluminum trim, the planter basket and the spillway from the upper section. Fig. 2

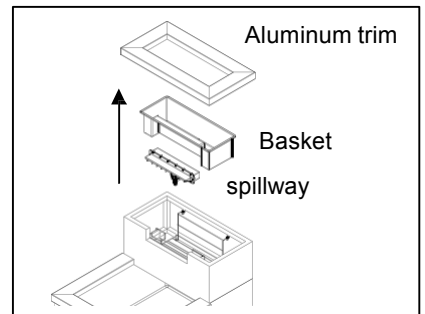

Fig. 2

3. Fasten the two sections together with the supplied fasteners. Fig. 3

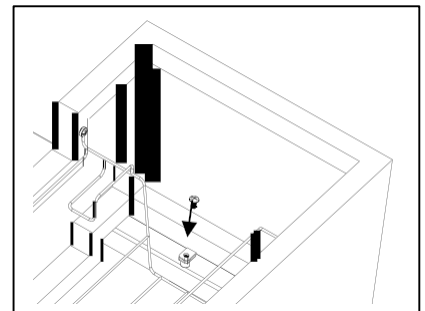

Fig. 3

4. For maximum water flow, cut the adapter as shown using a hacksaw. Fig. 4

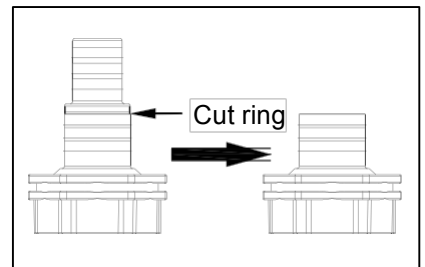

Fig. 4



PLEASE CALL 1-888-755-5641 BEFORE RETURNING TO THE STORE.

- Slip the hose clamp on to the tubing but do not tighten it. Connect the tubing to the inlet of the spillway using the adapter. Fig. 5

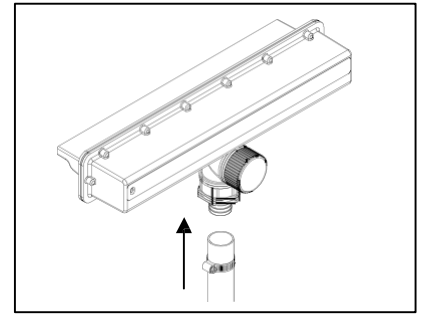

Fig. 5

- Tighten the hose clamp using a flathead screwdriver. Fig. 6

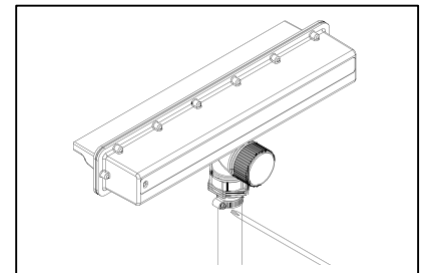

Fig. 6

- Place the spillway back inside the patio pond. Fig. 7

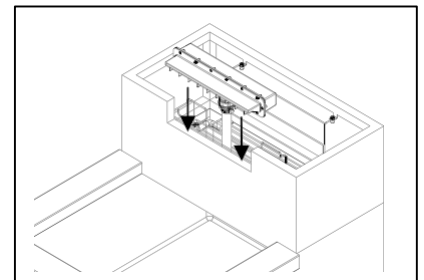

Fig. 7

- Remove the front screen from the pump and connect the prefilter to the front of the pump. Fig. 8

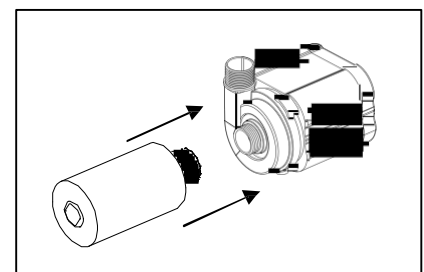

Fig. 8

- Place the pump inside the basin and connect the tubing to the pump. Fig. 9

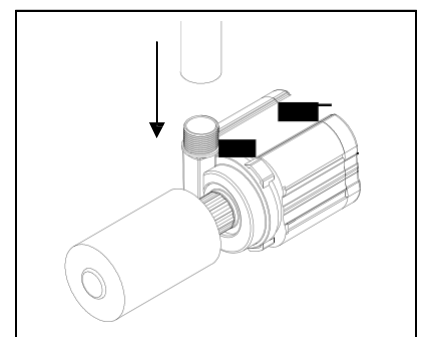

Fig. 9



PLEASE CALL 1-888-755-5641 BEFORE RETURNING TO THE STORE.

10. The planter basket has a drain hole. For indoor use, use the rubber stopper and insure it is seated properly. Fill it with water to insure there is no leakage. For outdoor use, do not use the rubber stopper instead connect the tube to the adapter. Fig. 10

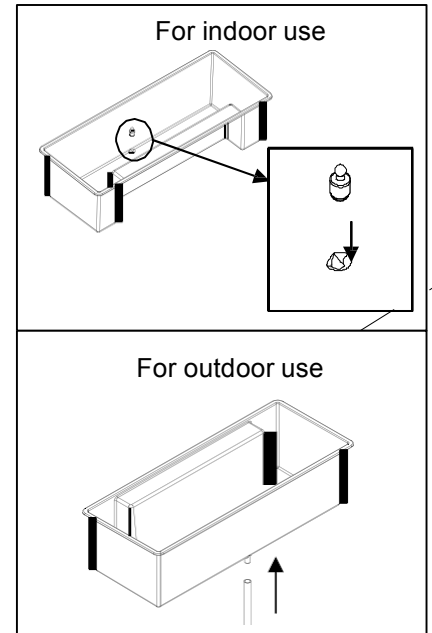

Fig. 10

11. Replace the basket on tray. Note: if the basket connect with the tube, it is important to insure that the planter drain tube is behind the liner of the reservoir to insure that dirt and debris from the planter do not enter the reservoir. Fig. 11

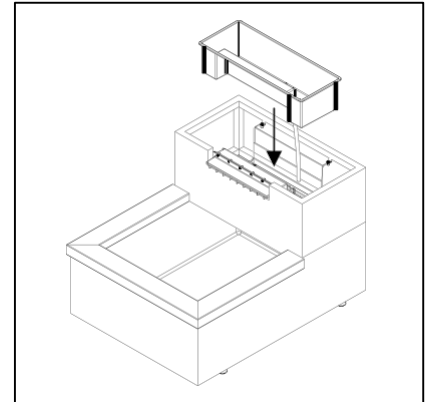

Fig. 11

12. Replace the aluminum trim on upper section. Fig.12

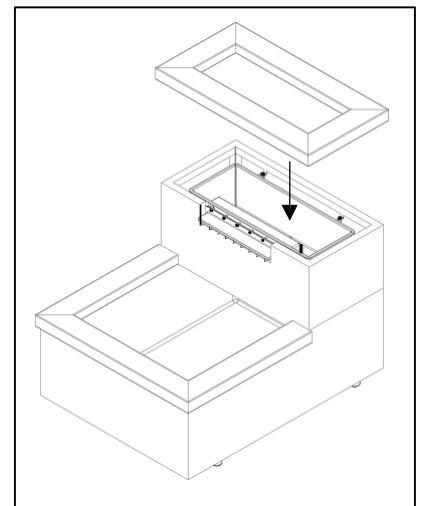

Fig. 12



PLEASE CALL 1-888-755-5641 BEFORE RETURNING TO THE STORE.

13. Route the cord of the pump and Illumifalls through the back rattan between the liner and the inside wall of the rattan. Fig. 13

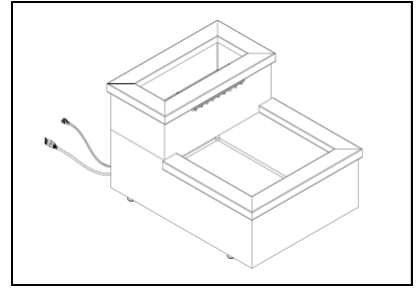

Fig. 13

14. Fill the basin with water, make sure that the plug on basin is closed. Check for leakage. If there is a leak, use the liner patch kit provided. Fig. 14

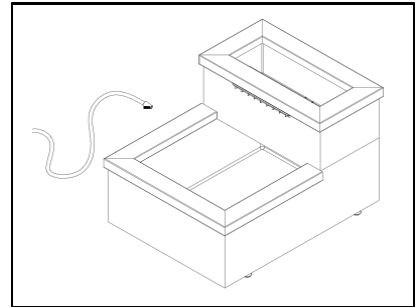

Fig. 14

15. Place plants in the planter basket. Fig. 15

NOTE: Plants are NOT INCLUDED.

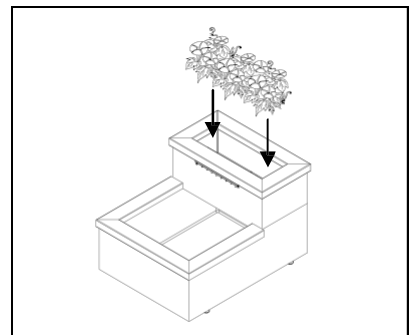

Fig. 15

16. Connect the spillway to the transformer by pushing the plug into the transformer socket until it is firmly seated. Hand tighten the nut from the plug to the socket. Fig. 16

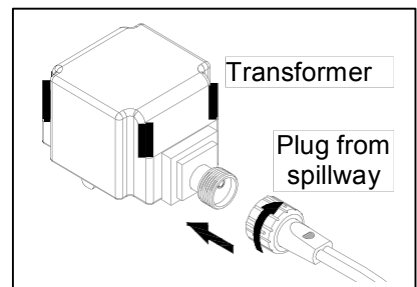

Fig. 16



17. Plug the transformer into a properly grounded electrical outlet.
Fig. 17

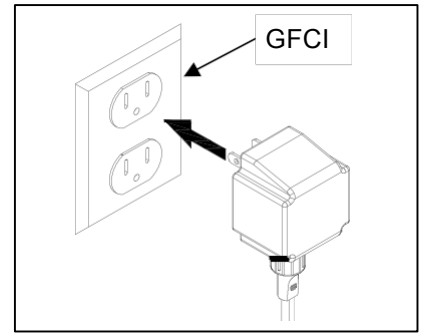

Fig. 17

18. Connect the pump to a proper power source. Fig. 18

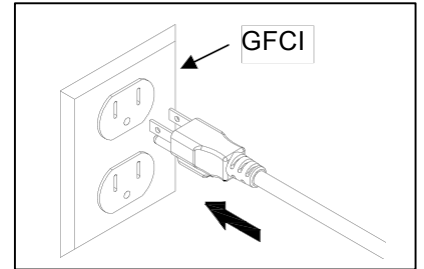

Fig. 18

19. Install the corner protectors by carefully bending the ends to fit around the frames. Fig. 19

NOTE: This step is optional. The corner protectors are meant to protect you from the sharp edges of the aluminum frames.

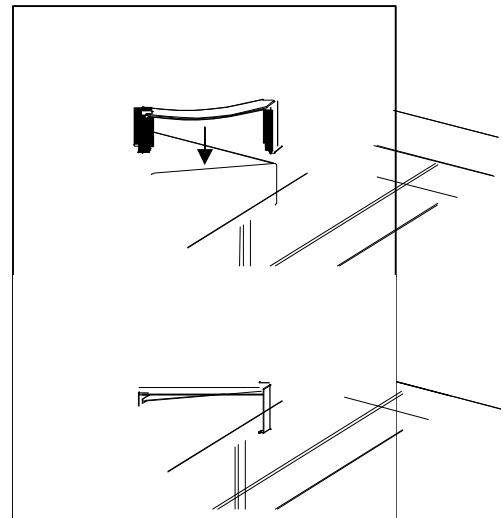

Fig. 19



CARE AND MAINTENANCE – PUMP

Clean the pump and filter regularly depending upon the environment in which it is operated. Clean the pump when it is visibly soiled or when a drop in performance is detected.

Before cleaning, always disconnect the pump from the power source.

Remove all parts from the pump and clean in warm, soapy water.

Disassemble the pump cover and remove the impeller cover to expose the impeller assembly. Use a soft cloth or brush to clean the impeller assembly and the inside of the impeller housing. Refer to the diagram in the replacement parts list.

CARE AND MAINTENANCE – SPILLWAY

Clean the spillway regularly depending upon the environment in which it is operated. Clean the spillway when it is visibly soiled or when a drop in performance is detected.

Before cleaning, always disconnect the transformer from the power source.

Use a dryer brush to clean the inside of the spillway. We recommend using a 3" long brush, approximately 1" thick or any brush that will fit inside the front of the spillway opening.

TROUBLESHOOTING

If the light fails to illuminate:

Check that it is getting power by testing another appliance in the same power outlet.

Check to make sure the spillway is properly connected to the transformer.

If the pump fails to operate:

Check to make sure the power cord is plugged in and the pump is getting power.

Check the pump outlet and any tubing, for kinks or obstructions.

Remove the inlet screen and/or pump cover, and impeller cover to expose the impeller. Turn the impeller to ensure that it is not broken or jammed. Also check to make sure that the ceramic shaft or bearings are not broken.

If the performance of the spillway is not satisfactory or does not flow evenly:

Check to make sure the pump is completely submerged in water.

Check to make sure the impeller and the housing are clean.

Check to make sure the spillway is clean.



PLEASE CALL 1-888-755-5641 BEFORE RETURNING TO THE STORE.

REPLACEMENT PARTS LIST

For replacement parts, call our customer service department at 1-888-755-5641, 8 a.m.-6 p.m., EST, Monday-Friday, or email us at customer care@gardendecor.com.

Part	Description
A	Pump
C	Hose clamp
E	Planter basket
I	Corner protector
J	Transformer
K	1" ID tubing (3 feet)
L	Stopper
M	1/2" tubing
N	Bolt
O	Liner patch kit
P	Filter pad
Q	Filter holder
R	Coupler
S	Inlet screen
T	Impeller housing
U	Impeller assembly
V	O-ring
W	Adapter gasket
X	Adapter
Y	Cap
Z	Waterfall gasket
A1	Tray
A2	Upper frame
A3	Left aluminum frame
A4	Right aluminum frame
A5	Bracket
A6	Front/back aluminum frame
A7	Left dowel
A8	Front/back dowel
A9	Left bottom aluminum frame
A10	Right bottom aluminum frame
A11	Cap-bottom aluminum frame
A12	Right dowel
A13	Liner
A14	Lower frame
A15	Clip
A16	Screw
A17	Foot

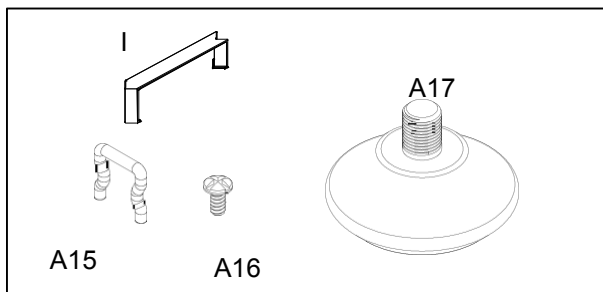
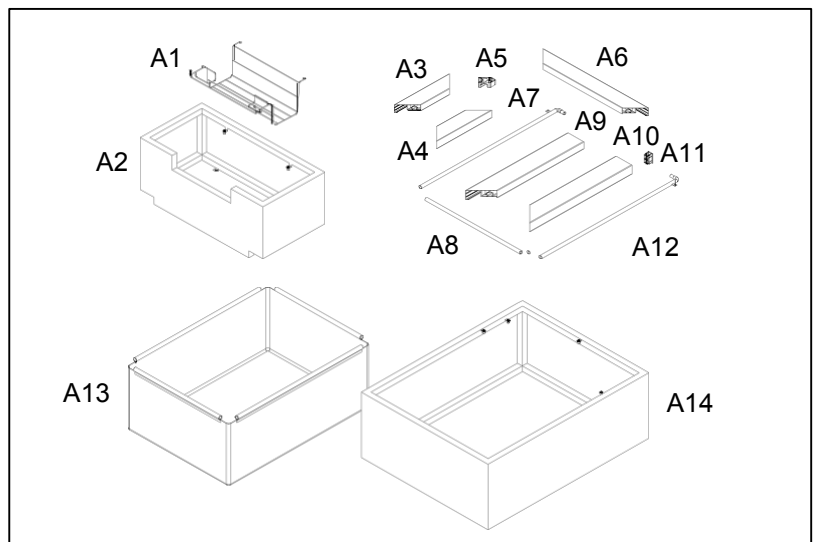
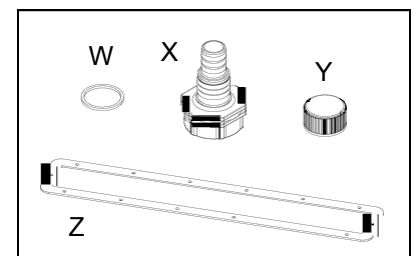
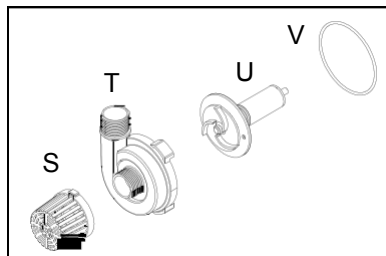
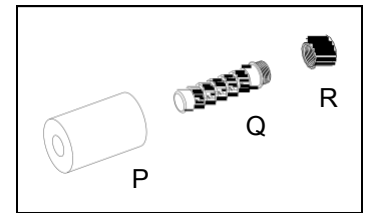
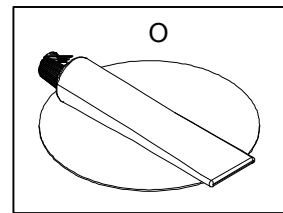
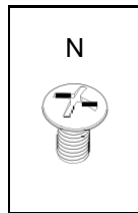
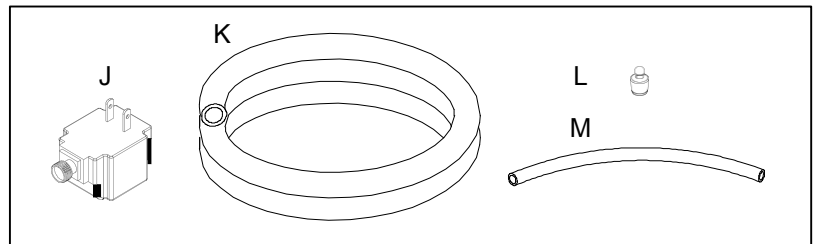
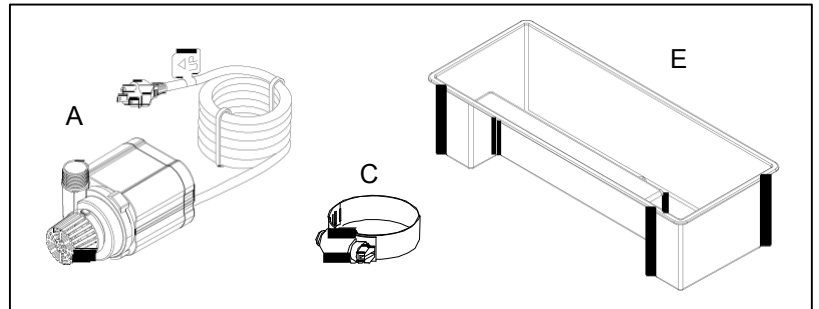

Printed in China



PLEASE CALL 1-888-755-5641 BEFORE RETURNING TO THE STORE.

LIMITED WARRANTY

All pumps and electrical products are warranted to the user against defective material and workmanship, under normal working conditions. This warranty period begins on the date of purchase by the original purchaser.

Unless otherwise specified all GARDENIQUE® electrical products are warranted to the user against defective material and workmanship, under normal working conditions for 1 year from the date of purchase.

- Pond and Waterfall pumps are warranted for 3 years.
- GARDENIQUE® liners are warranted to the user against defective workmanship, under normal working conditions for 20 years from the date of purchase.
- All other GARDENIQUE® products are warranted to the user against defective material and workmanship, under normal working conditions for 90 days.

Application

Warranty covers only properly installed and maintained units. Any damage to the cord or modification to the unit will invalidate the warranty. Pump warranty is limited to applications pumping fresh water in a pond or fountain only. Other liquid applications or extreme temperature uses must be approved in writing by the manufacturer. Receipt and product date code are required for warranty claims.

Warranty Claim

Warranty claims must be made by calling customer service (at 1-888-755-5641). If the item is determined to be defective, you will be given authorization to return the defective part(s), freight pre-paid, along with proof of purchase.

Disposition

The manufacturer will make a good faith effort for prompt disposition regarding all warranty claims. Returned product will be inspected to determine cause of failure before warranty is applied. Warranty does not cover any costs associated with the shipping, handling, installation or removal of products or parts subject to this warranty. For products damaged in transit, a claim should be filed with the carrier.

Disclaimer

Any oral statements made about the product by the seller, the manufacturer, the representatives, or any other parties do not constitute warranties, should not be relied upon by the user, and are not part of the contract for sale. The seller's and manufacturer's only obligation, and buyer's only remedy shall be for the manufacturer to either replace and/or repair at the manufacturer's sole discretion, the product as described above. Neither seller nor the manufacturer shall be liable for injury, loss or damages for lost profits, lost sales, injury to person or property, or any other incidental or consequential loss arising from any cause whatsoever, no matter whether based upon warranty, contract, negligence or other misuse, and the buyer and user agree that no other remedy shall be available to them. Before using, the buyer and user shall determine the suitability of the product for the intended use, and assume all risk and liability whatsoever in connection therewith. The warranty and remedy described in this limited warranty is an exclusive warranty and remedy in lieu of any other warranty or remedy expressed or implied. All other warranties and remedies are hereby expressly excluded, including but not limited to any implied warranty of merchantability of fitness for any particular purpose. This warranty gives the buyer and user specific legal rights, and buyer and user may also have other rights which vary from state to state. Some states do not allow exclusions or limitations of incidental or consequential damages, so the above limitations or exclusions may not apply to you.

REMINDER
CALL 1-888-755-5641
BEFORE RETURNING TO STORE.



PLEASE CALL 1-888-755-5641 BEFORE RETURNING TO THE STORE.